

CCWR retrofit wireless kit



product description

The CCWR is a wireless communication kit that can be retrofitted to any existing POC load cell currently in use in pump-off control systems within the oil and gas industry

The purpose of the kit is to replace the conventional wired connection, which can degrade over time due to the repetitive motion of the pump jack. The CCWR eliminates the cable by creating a wireless connection between the POC load cell and the base unit, located inside or near the controller box. This means eliminating costly well shutdown due to cable failure.

The CCWR comprises of two parts; the remote wireless unit which attaches to the load cell, as well as the base unit which is mounted nearby.

The CCWR is at the forefront of wireless technology in the current market. It has extremely low power consumption and a long battery life, delivering a continuous flow of data with exceptional signal strength. It features a position-sensing capability, which is synchronized with the load measurement, eliminating the need for hall effect sensors or inclinometers.

The unit comes in a robust enclosure ideal for harsh environmental conditions. The battery compartment is easily accessible and holds an inexpensive and readily available D-cell battery.

applications

Pump off control systems



RoHS
compliant



key features

Compatible with CC1/CC3 load cells

100 – 1,000ft (30-300m) range

100 readings per second

Position sensing capability

12 to 18-month battery life

High signal strength

Encrypted communication

Environmental protection to IP67

Rated -70° to 175°F (-55° to 80°C)

approvals

UL Approved Class 1, Div 1 (pending)

FC Approval (pending)

specifications

Typical System Specifications with Flintec CC1 and CC3

Variants/Capacities	lb	30k & 50k
Rated Load Output (RO)	mV/V	2.00 ± 0.5%
Rated Position Output	% FS (Stroke)	± 0.5
Non-Repeatability	% RO	± 0.1 min
Static Error Band	% FS Max	± 0.50
Compensated Temperature Range	°F (°C)	-14° to 150° (-25° to 65°)
Safe Operating Temperature Range	°F (°C)	-70° to 175° (-55° to 80°)
Temperature Effect on Zero	% RO/°F Max	± 0.005
Temperature Effect on Output	%RO/°F Max	± 0.002
Zero Balance	% RO Max	± 1
Weight, (Appr. Remote Unit + LC e.g. CC1)	lb Nom.	4.2
Fatigue Rating (compression)	Cycles Min@Capacity	50,000,000
Shock Rating	g	Up to 500g
Vibration Rating	MIL-STD-810G	514.6; 516.6

Load-Cell Requirements

Rated Load Output (Nominal RO)	mV/V	2
Excitation Voltage	V	+5V _{DC} to +10V _{DC}
Insulation Resistance (100V _{DC})	MΩ	≥500
Bridge Resistance	Ω	≥ 350
Protection According to EN 60529		IP67

Electronics Specification

Remote and Base Transceiver Units Matched	Mac ID	(32bit) Specific; No External Connection - Paired Unit
Data Rate	Readings/Sec	100
Radio Frequency Band	GHz	2.45
Radio Channels	Selectable (*)	14
Telemetry Range	Feet (Meters) (*)	100 - 1000 (30-300)

RF Power Output- Remote Unit	dBm (*)	13-15.5
RF Power Output- Base Unit	dBm (*)	12.5-14
Remote Unit Battery Life	Min @ 100 rps (**)	12 to 18 months
Remote Unit Battery Type		(TL-5930/F) Lithium D-Cell, 3.6V _{DC} , 19Ah
Compensated Temperature Range	°F (°C)	-14° to 150° (-25° to 65°)
Operating Temperature Range	°F (°C)	-70° to 175° (-55° to 80°)
Base Unit		
Power Supply	VDC, mA	12 - 24 ; Min. 250mA
External Ref. (Virtual Excitation) Voltage	VDC	4.8-10.1
Virtual Bridge Resistance	Ω	700
Protection According to EN 60529		IP67 or higher
(*) 2-3dBm; Telemetry range will change according to site RF Channel Settings		
(**) Battery Life changes as per RF output; latency; Temp; antenna distances etc. Refer to Manufacturer for details.		

product dimensions (mm)

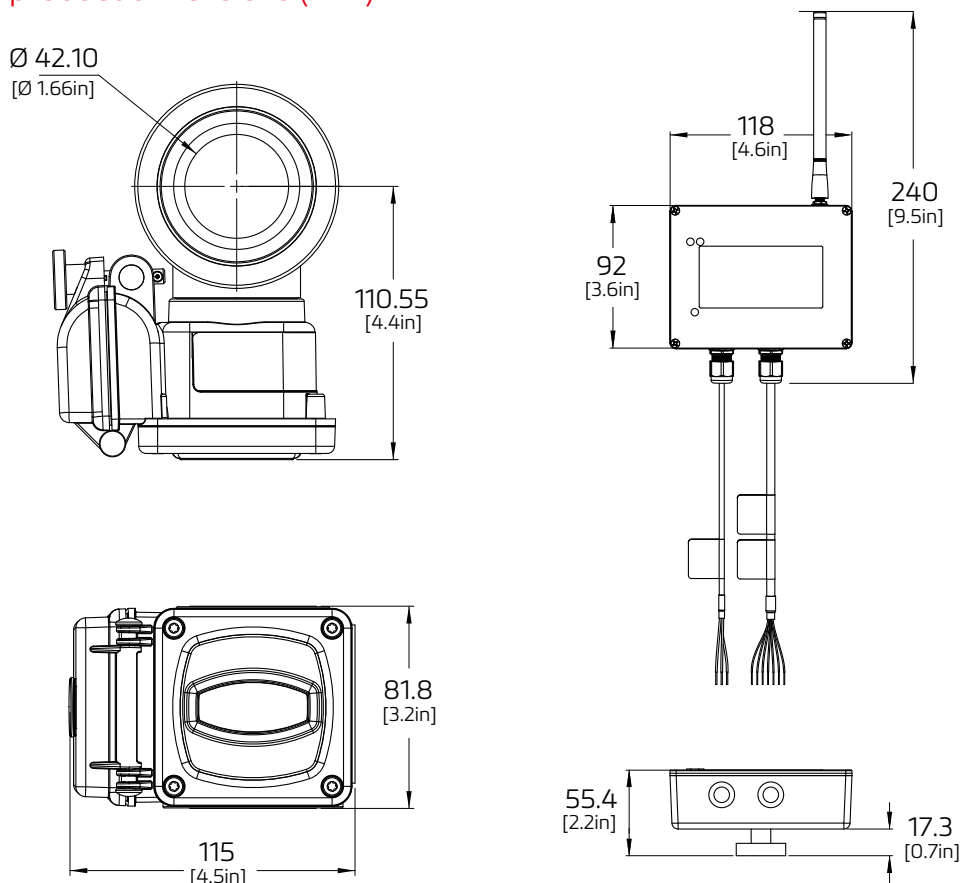

included in the kit

- Remote wireless unit
- Base/Receiver unit
- Antenna & connection cables
- Lithium battery
- Magnetic or post mount for Base (user specified)
- Load spacer/plate
- Spherical washer set

*Dimensions shown here include the CC1 load cell.

Specifications and dimensions are subject to change without notice.